

Load Switch N 512 8 x 20A @ 277Vac / 347Vac 5WG1 512-1CB01

June 2015 / Page 1

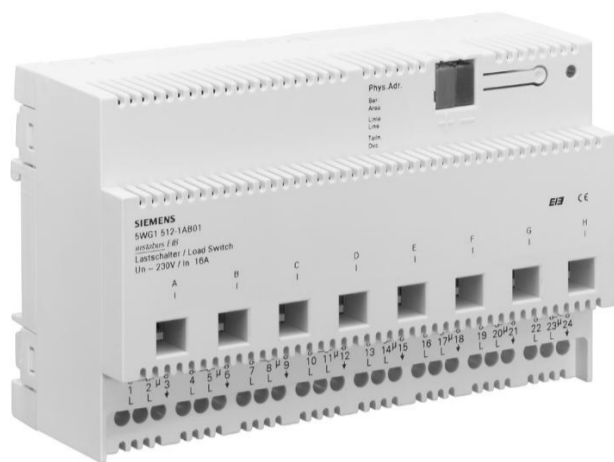

Product and Applications Description

The load switch N 512 is a DIN-rail mounted device for the *instabus* EIB lighting control panel. Via its eight outputs it can switch eight separate groups of electric devices.

The control power supply of the load switch N 512 is provided by the bus (i.e., it requires no additional power supply).

The outputs may be operated manually via slide switches. These switches also show the actual switching state (when switching manually as well as when switching via the bus). Each of the outputs (relays) can be assigned various tasks depending on the application program used, i.e. the load switch N 512 consists of the device (hardware) and its application programs (software).

The load switch N 512 can handle different tasks; e.g. non-delayed on and off switching.

With the ETS (EIB Tool Software) the application program is selected, its parameters and addresses are assigned appropriately, and downloaded to the load switch N 512.

Application Programs

20 A8 Binary with Status 900701

Available functions per output:

- Logical functions (AND/OR) can be set
- defined pre-set initial value of the voltage restoration
- initial value of the relation at bus voltage recurrence
- on/off -delay mode available
- operation mode of the relay: NO/NC
- operation mode: normal / timer
- characteristic in case of bus voltage failure/bus voltage restoration can be set in parameter list

Technical Specifications

Control power supply
class 2 via bus line

Device Rating
480 Vac

Outputs

- 8 independent load switches (bistable relays)
- rated voltage: 12 - 277 Vac / 347Vac, 50 / 60 Hz
- switching characteristic: set in parameter list according to application program

Maximum loads per output

20 A @ 347 Vac (General Purpose)
20 A @ 347 Vac Ballast (200µF max.)
20 A @ 277 Vac (General Purpose)
20 A @ 277 Vac Ballast (200µF max.)
1,5 HP @ 120 Vac
3 HP @ 277 Vac

Control elements

- 1 learning button for switching between normal operating mode and addressing mode
- 8 slide switches for manual operation

Display elements

- 1 red LED for monitoring bus voltage and displaying mode, selected with the learning button
- 8 slide switches providing switching state information

Connections

- load circuit, physical: AWG# 14-12 solid or stranded Cu
- bus line,
 - one screwless bus connection block AWG #20-18 solid Cu
 - pressure contacts on data rail

Physical specifications

- polymer casing
- DIN-rail mounted device, width: 8 SU
1 System unit (SU) = 18mm
- weight: approx. 560 g (20oz)
- installation: rapid mounting on DIN EN 50022-35 x 7,5 rail

Electromagnetic compatibility

complies with Part 15 of the FCC rules pursuant to the limits for a Class A digital device

Environmental specifications

- ambient temperature operating: - 5 - + 45 °C (23-113°F)
- maximum ambient temperature range: - 25 - + 70 °C (-13-158°F)
- relative humidity (non-condensing): 5 % to 93 %

Listings and Certifications

UL listed (E464611)

UL 916, Open Energy Management Equipment

CSA certified

CE marked

In accordance with the EMC guideline (residential and functional buildings) and the low voltage guideline.

KNX / EIB certified

Markings

KNX, EIB, CE, UL

Load Switch N 512
 8 x 20A @ 277Vac / 347Vac
 5WG1 512-1CB01

Location and Function of the Control Elements and Display

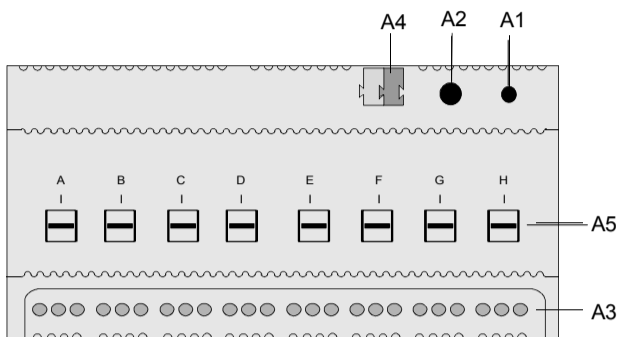

- A1 LED for indicating normal operating mode (LED off) and addressing mode (LED on); upon receiving the physical address the device automatically returns to normal operating mode
- A2 Learning button for switching between normal operating mode and addressing mode
- A3 mains connection blocks (screw terminals) for connecting load circuits
- A4 bus connection block, screwless
- A5 Slide switches for manual operation and for displaying the switching position.
 Slide to position 1 : relay contact closed
 Slide to position opposite to 1 : relay contact open
 Manual operating of the switches will be overwritten by a switching command from the bus.

Typical circuit

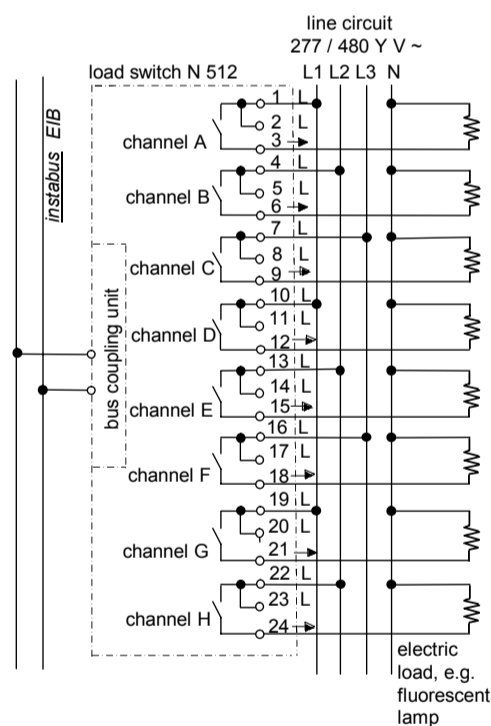

Installation Instructions

The device may be used for permanent interior installations in dry locations within distribution boards or small casings with DIN rail EN 60715-TH35-7,5. This equipment is intended for field installation within the enclosure of another product.

WARNING

Hazardous voltage. Can cause death, or serious injury or property damage. Disconnect and lock off power before installing or working on the device. Risk of Electric Shock – More than one disconnect switch may be required to de-energize the equipment before servicing.

The device must not be opened. A faulty device should be returned to the local Siemens sales office or distributor.

The device must be mounted and commissioned by a factory trained person. The prevailing safety rules must be observed! Mount in dry locations only!

Mounting

General description

The DIN-rail device (8 SUs) can be installed in the *instabus* EIB lighting control panel, surface or flush mounted, or snapped onto any available DIN-rail EN 50022-35 x 7,5. The connection to the bus line is established by bus connection blocks or by clicking the device onto the DIN-rail (with a data rail installed). Take care that the type plates of all devices on a DIN-rail can be read in the same direction, guaranteeing the devices are polarised correctly. If the connection is only established via bus connection blocks (A4) and the data rail is not installed the contacting system (D2) towards the data-rail has to be covered by removing the guide top e.g. (D3) with a screw-driver and afterwards snapping on the insulation top (D4) to ensure a sufficient insulation towards the DIN-rail. In this case the unsally employed connector module N191 is not necessary. The bus connection block (A4) is internally connected to the contact system (D2).

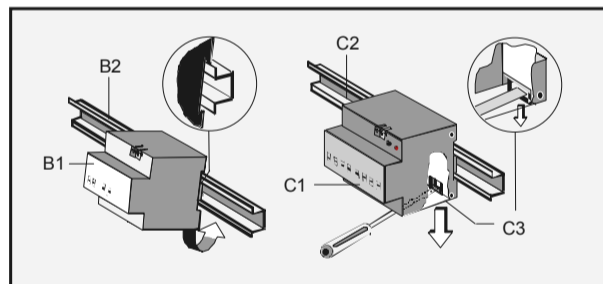

Mounting the Load Switch unit N 512 to a DIN-rail

- Slide the DIN-rail device (B1) onto the DIN-rail (B2) and swivel the DIN-rail device until the slide clicks into place audibly

Dismounting DIN-rail devices

- Remove all connected wires, Press the slide (C3) with a screw-driver away from the device and swivel the DIN – rail device (C1) from the DIN – rail (C2).

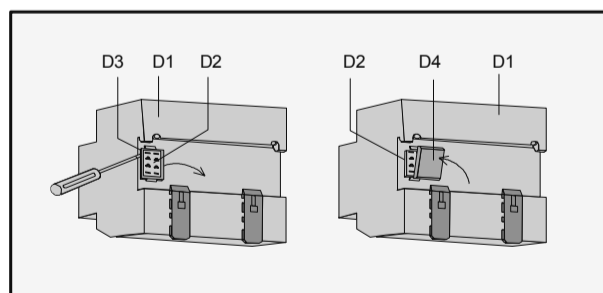

Removing the guiding top

- The guiding top (D3) surrounds the contact system (D2) on the back side of the load switch N 512 (D1).
- Insert the screw driver between the DIN-rail device (D1) and the guiding hood (D3) and remove the guiding hood.

Inserting the insulation top

- Put the insulation top (D4) onto the contact system and click it into place by slight pressure

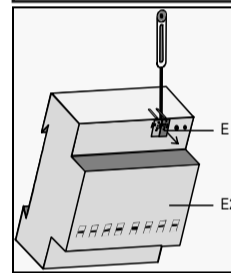
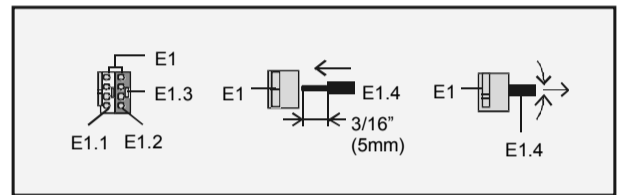

Wiring

Slipping off bus connection blocks

- The bus connection block (E1) is situated on the top of the Load Switch unit N 512 (E2).
- The bus connection block (E1) consists of two components (E1.1 and E1.2) with four terminal contacts each. Take care not to damage the two test sockets (E1.3) by accidentally connecting them to the bus cable or with the screw-driver (e.g. when attempting to unplug the bus connection block).
- Carefully put the screw-driver to the wire-inserting slit of the bus connection block's grey component and pull the bus connection block (E1) from the Load Switch unit N 512 (E2).

Slipping on bus connection blocks

- Slip the bus connection block onto the guide slot and press the bus connection block down to the stop.

Connecting bus cables

- The bus connection block (E1) requires AWG 20-18 solid Cu e.g. Belden # 6230 FE.
- Remove approx. 3/16" (5mm) of insulation from the conductor (E1.4) and plug it into the bus connection block (E1) (red = +, black = -).

Disconnecting bus cables

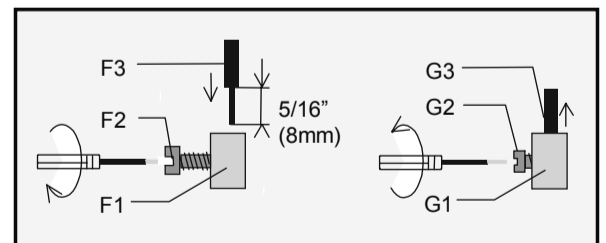

Unplug the bus connection block (E1) and remove the bus cable conductor (E1.4) while simultaneously wiggling it

Connecting load circuits

Remove approx. 5/16" (8mm) of insulation from the wire (F3), plug it into the terminal (F1) and tighten the screws (F2). Torque for terminals 7 lb – in.

Disconnect load circuits

- Loosen the screw (G2) and slip the conductor (G3) out of the block (G1).

Important remark

A faulty device should be returned to the local Siemens sales office or distributor.