

## Binary Output (Relay) JB510C23

5WG1510-4CB23

April 2020 / Page 1



### Product and Applications Description

The JB510C23 Binary Output (Relay) is a KNX device with two switching outputs. The device is installed in a 4 x 4 inch junction box. The bus is connected via a bus terminal block. The actuator electronics are supplied via the bus voltage.

The JB510C23 can switch resistive loads (e.g. electrical heaters, incandescent lamps, high voltage halogen lamps), inductive loads (e.g. motor, low voltage halogen lamps with intermediate conventional transformers), or capacitive loads (e.g. low voltage halogen lamps with intermediate electronic transformers).

Each actuator output may be configured independently to provide switching, manual override, forced control, logical gate and status reporting. Furthermore, if required, time-limited switching instead of permanent switching on can be enabled for each channel via an optional "Night mode" object (e.g. for lighting while cleaning), if need be with a warning before switching off by multiple switching the output on and off (flashing).

Amongst others, the application program includes an optional count of switching cycles and operating hours with threshold monitoring for each output and an integrated 8-bit scene control, in which the output can be incorporated into up to 8 scenes.

Each output of the actuator may be set to one of the following operating modes:

- Normal operation
- Timer operation

### Building site function

The building site function provided ex-factory enables switching the building site lighting on and off via bus wall switches and actuators, even if these devices have not yet been commissioned with ETS.

### Application Program

The JB510C23 Binary Output (Relay) needs the application program "07 B0 A2 Switching Actuator 982E02".

### Example of Operation

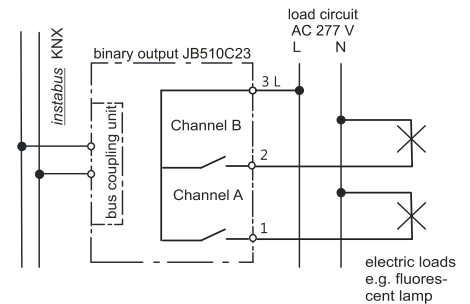

### Technical Specifications

#### Power supply

- via the bus line
- KNX bus voltage: DC 24V (DC 21...30V) via KNX/EIB bus line
- KNX bus current: < 10 mA

#### Outputs

- 2 outputs (potential-free, bistable relay contacts)
- switching characteristic: set in parameter list according to application program
- rated voltage: AC 120-277V, 50/60Hz
- rated current: 10A resistive load
- switching current at AC 277V: 0.01 ... 10A resistive load
- switching current at DC 24V:
  - 10A resistive load
  - 4A inductive load (L/R = 7ms)
- max. relay position changes per minute: 60

#### Maximum load per output

- 10 A @ 120 Vac (General Purpose)
- 10 A @ 120 Vac Ballast (14µF max.)
- 8 A @ 277 Vac (General Purpose)
- 10 A @ 277 Vac Ballast (14µF max.)
- 1 HP @ 277 Vac

#### Control elements

1 learning button:  
for switching between normal operating mode and addressing mode

#### Display elements

1 red LED:  
for monitoring bus voltage and for displaying normal mode/addressing mode

### Connections

- Bus line : Bus connection pins for connection of the screwless bus terminal block (red-black) 0.6...0.8 mm Ø single core, strip insulation 5mm
- Load circuit: see Location and Function of Interface Elements

### Physical specifications

- housing: plastic
- dimensions (L x W x D):
  - length : 70 mm (2.76 inch)
  - width : 90 mm (3.54 inch)
  - depth: 44,6 inch (1.76 inch)
- weight: approx. 156 g
- fire load: approx. 5 MJ
- Installation: in a junction box (min. dimensions (L-W-D))
  - Length: 4 inch (101.6 mm)
  - Width: 4 inch (101.6 mm)
  - Depth: 2 inch (50.8 mm)

### Electrical safety

- Degree of pollution (according to IEC 60664-1): 2
- Type of protection (according to EN 60529): IP 20
- Overvoltage category (according to IEC 60664-1): III
- Bus: safety extra low voltage SELV DC 24 V
- Device complies with: EN 50428

### Electromagnetic compatibility

complies with EN 50428

### Environmental specifications

- Ambient operating temperature:
  - 5 ... + 45 °C (+ 23 ... + 113 °F)
- Storage temperature:
  - 25 ... + 70 °C (- 13 ... + 158 °F)
- Relative humidity (not condensing): 5 % ... 93 %

### Reliability

- Failure rate: 318 fit at 40°C

### Markings

EIB, KNX, UL

### Listings and Certifications

#### CE mark

complies with the EMC regulations (residential and functional buildings) and low voltage regulations

#### UL listed (E464611)

UL 916, Open Energy Management Equipment

Location and Function of the Interface Elements

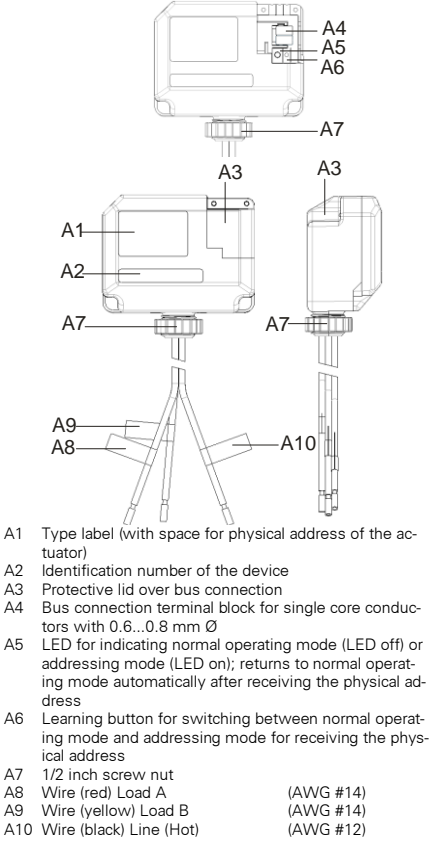

Dimension Diagram

Dimensions in mm (inch)

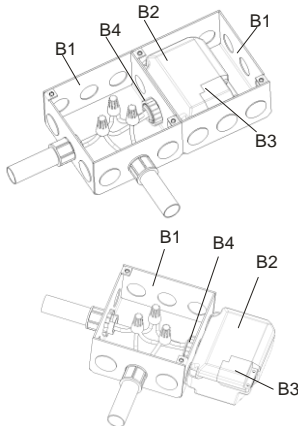
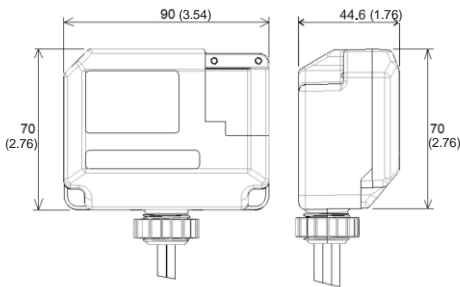

Mounting and Dismounting

- Mounting of a JB module:
  - Option 1 (mounting inside a J-Box)
    - Insert the thread of the JB module (B2) into the 1/2 inch knockout between two adjacent J-Boxes (B1)
    - Fasten the JB module (B2) with the 1/2 inch thread nut (B4)
    - Remove the protective lid (B3) and connect the bus wire to the bus terminal block (A4)
    - Connect the wires from the device to the field wires using wire nuts (not provided in package)
  - Option 2 (mounting outside of a J-Box)
    - Insert the thread of the JB module (B2) into the 1/2 inch knockout of the J-Box (B1)
    - Fasten the JB module (B2) with the 1/2 inch thread nut (B4) to the J-Box (B1)
    - Connect the bus wire to the bus terminal block under the protective cover (B3)
    - Connect the wires from the device to the field wires using wire nuts (not provided in package)
- Assignment of the Physical Address:
  - A short push (< 2 s) of learning button (A6) enables the addressing mode, which is indicated when the LED is continuously on (A5). The device returns to normal operating mode (LED Off) automatically after receiving the physical address or if the learning button is pushed again.
  - A very long push (> 20 s) of the learning button resets the device to factory settings. This is indicated by constant flashing for 8 seconds.
  - A long push (> 5 s up to 20 s) of the learning button enables the Connection Test for commissioning with Desigo. This mode can be disabled by a short push any time.
  - Install the protective lid (B3) and fasten with screws (provided in package)
- Dismounting a JB module:
  - Disconnect power to the module
  - Remove the wire nuts and bus connection
  - Unfasten the 1/2 inch thread nut (B4) connecting the JB module (B2) to the J-Box (B1)
  - Remove the JB module (B2) from the J-Box (B1)

Wiring

Slipping off/on bus connection blocks

The bus connection block consists of two components (C2.1 and C2.2) with four terminal contacts each. Take care not to damage the two test sockets (C2.3) by accidentally connecting them to the bus cable or with the screw driver (e.g. when attempting to unplug the bus connection block).

Slipping off bus connection blocks

- Carefully put the screw driver to the wire insertion slit of the bus connection block's grey component (C2.2) and
- pull the bus connection block (C2) from the module.

## WARNING

**Hazardous voltage.**  
Can cause death, or serious injury or property damage.

**The device must not be opened.**  
A faulty device should be returned to the local Siemens sales office or distributor.

**The device must be mounted and commissioned by a factory trained person.**  
The prevailing safety rules must be observed!  
Mount in dry locations only!

Note

Don't try to remove the bus connection block from the bottom side. There is a risk of shorting-out the device!

Slipping on bus connection blocks

- Slip the bus connection block (C2) onto the guide slot of the module and
- press the bus connection block (C2) down to the stop.

Connecting and Disconnecting bus cables

Connecting bus cables

- The bus connection block (D1) can be used with single core conductors Ø 0.6...0.8 mm.
- Remove approx. 5 mm of insulation from the conductor (D2) and plug it into the bus connection block (D1) (red = +, grey = -)

Disconnecting bus cables

- Unplug the bus connection block (D1) and remove the bus cable conductor (D2) while simultaneously wiggling it.

Connecting mains and load circuit:

Connect wires

- Connect wire leads using wire nuts.

Electromagnetic compatibility

USA:

This device complies with part 15 of the FCC Rules. Operation is subject to the following two conditions:

- (1) This device may not cause harmful interference, and
- (2) this device must accept any interference received, including interference that may cause undesired operation.

This equipment has been tested and found to comply with the limits for a Class B digital device, pursuant to part 15 of the FCC Rules. These limits are designed to provide reasonable protection against harmful interference in a residential installation. This equipment generates, uses and can radiate radio frequency energy and, if not installed and used in accordance with the instructions, may cause harmful interference to radio communications. However, there is no guarantee that interference will not occur in a particular installation. If this equipment does cause harmful interference to radio or television reception, which can be determined by turning the equipment off and on, the user is encouraged to try to correct the interference by one or more of the following measures:

- Reorient or relocate the receiving antenna.
- Increase the separation between the equipment and receiver.
- Connect the equipment into an outlet on a circuit different from that to which the receiver is connected.
- Consult the dealer or an experienced radio/TV technician for help.

This device complies with Part 15 of the FCC rules. Changes or modifications not expressly approved by Siemens Schweiz AG could void the user's authority to operate the equipment.

United States representative:  
<https://new.siemens.com/us/en/products/buildingtechnologies/home.html>

Canada:  
 CAN ICES-3(B)/NMB-3(B)