

## Switch/Dim Actuator JB 526C23, 2 x AC 277 V 5WG1526-4CB23

February 2022



### Product and Applications Description

The device is a KNX device for controlling up to two groups (channels) of lamps via the DC 0/1-10 V control terminal of dimmable led drivers (ECGs). In addition, there is per channel a switching contact for direct switching on/off of the connected lamps.

The device is installed into or attached to a 4 x 4 inch junction box. The bus is connected via a bus terminal block. The actuator electronics are supplied via the bus voltage. Each channel can control several dimmable electronic ballasts. Their number is limited by the switching capacity and by the control power. If the on/off function is not used via the switching contact, the number of controllable ECGs is only dependent on the load of the DC 0/1-10 V control voltage. This might allow controlling a larger number of drivers (see Technical Specifications below).

Various functions can be configured per channel such as for switching on/off lamps, dimming up / down or setting a particular dimming level.

Amongst others, the application program includes an optional counter for switching cycles and operating hours with threshold monitoring for each output and an integrated 8-bit scene control for incorporating the output into up to 8 scenes.



### Configuration

The device can be configured with Desigo Room Automation commissioning tool (ABT) or with KNX Engineering Tool Software (ETS).

### Example of Operation

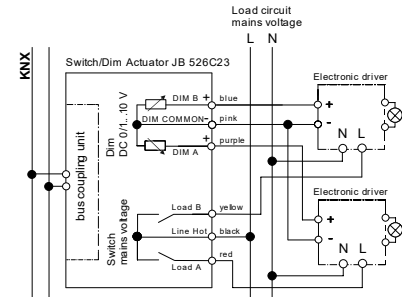

### Technical Specifications

#### Power supply

- KNX bus voltage: via the bus line
- KNX bus voltage: DC 24 V (DC 21...30 V) via KNX bus line
- KNX bus current: < 10 mA

#### Outputs

- 2 outputs (potential-free contact, bistable relays)
- switching characteristic: set in parameter list according to application program
- rated voltage: 120, 277, 347 Vac, 50 / 60 Hz

#### Maximum load

- max. current per unit: 20A
- 20 A @ 347 Vac (General Purpose)
- 20 A @ 347 Vac Magnetic Ballast (200µF max.)
- 20 A @ 277 Vac (General Purpose)
- 20 A @ 277 Vac Ballast (200µF max.)
- 20 A @ 120 Vac (General Purpose)
- 20 A @ 120 Vac Ballast (200µF max.)

#### Control voltage

- 0/1 ... 10 V (provided by dimmable driver)
- in case of bus voltage failure: 10 V

#### Control power per channel

- dimmable electronic ballast according to IEC 60929 Annex E.2 or signal amplifier:
  - max. 100mA @ 25°C (70°F) e.g. 50 units 2mA each
  - max. 85mA @ 45°C
  - Derating curve is linear
- Protection against destruction by accidental connection to mains voltage!

#### Control elements

1 PROGRAMMING BUTTON: for switching between normal operating mode and programming mode

#### Display elements

1 RED LED: for monitoring bus voltage and for displaying normal mode/programming mode

#### Connections

KNX Bus: screwless "Push-Connect" standard KNX terminal block (red/black). Connect can fit 4 pairs of terminations

BUS Wire: 18-22 AWG (0.6...0.8 mm) solid core, twisted, shielded wire - strip insulation 5 mm.

Siemens wire: KNX-TSP20LC-CMP

Load circuit:

see Location and Function of Interface Elements

#### Physical specifications

- housing: plastic
- dimensions:
  - length: 70 mm (2.76 inch)
  - width: 90 mm (3.54 inch)
  - depth: 44.6 mm (1.76 inch)
  - weight: approx. 245 g (9 oz)
- fire load: approx. 6 MJ
- installation: in a junction box
- minimal dimensions:
  - length: 4 inch (101.6 mm)
  - width: 4 inch (101.6 mm)
  - depth: 2-1/8 inch (54 mm)

#### Environmental specifications

- Ambient operating temperature:
  - 5 ... + 45 °C (+ 23 ... + 113 °F)
- Storage temperature:
  - 25 ... + 70 °C (- 13 ... + 158 °F)
- Relative humidity (not condensing): 5 % ... 93 %

#### Reliability

- Failure rate: 461 FIT at +40°C (104°F)

#### Electrical safety

- Degree of pollution (according to IEC 60664-1): 2
- Type of protection (according to IEC 60529): IP20
- Overvoltage category (according to IEC 60664-1): III
- Bus: safety extra low voltage SELV DC 24 V
- Device complies with: IEC61558-2-16, EN 50491-3

### Listings and Certifications

#### Markings

KNX, UL, cUL, PLENUM RATED

#### UL listed (E464611)

UL 916 Enclosed Energy Management Equipment

UL 2043 Plenum Rated - Suitable for installation in Air Handling or Plenum spaces

#### Electromagnetic compatibility

##### USA:

This device complies with part 15 of the FCC Rules. Operation is subject to the following two conditions:

- (1) This device may not cause harmful interference, and
  - (2) this device must accept any interference received, including interference that may cause undesired operation.
- This equipment has been tested and found to comply with the limits for a Class B digital device, pursuant to part 15 of the FCC Rules. These limits are designed to provide reasonable protection against harmful interference in a residential installation. This equipment generates, uses, and can radiate radio frequency energy and, if not installed and used in accordance with the instructions, may cause harmful interference to radio communications. However, there is no guarantee that interference will not occur in a particular installation. If this equipment does cause harmful interference to radio or television reception, which can be determined by turning the equipment off and on, the user is encouraged to try to correct the interference by one or more of the following measures:
- Reorient or relocate the receiving antenna.
  - Increase the separation between the equipment and receiver.
  - Connect the equipment into an outlet on a circuit different from that to which the receiver is connected.
  - Consult the dealer or an experienced radio/TV technician for help.

This device complies with Part 15 of the FCC rules. Changes or modifications not expressly approved by Siemens Schweiz AG could void the user's authority to operate the equipment.

United States representative:  
<https://new.siemens.com/us/en/products/buildingtechnologies/home.html>

Canada:  
CAN ICES-3(B)/NMB-3(B)





# WARNING

**Hazardous voltage.**  
Can cause death, or serious injury or property damage.

**The device must not be opened.**  
A faulty device should be returned to the local Siemens sales office or distributor.

**The device must be mounted and commissioned by a factory trained person.**  
The prevailing safety rules must be observed!  
Mount in dry locations only!

## Switch/Dim Actuator

JB 526C23, 2 x AC 277 V

5WG1526-4CB23

February 2022

### Location and Function of the Interface Elements

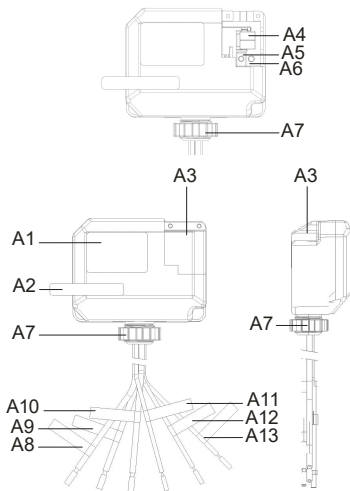

- A1 Type label (with space for physical address of the actuator)
- A2 Identification number of the device
- A3 Protective lid over bus connection
- A4 Bus connection terminal block for single core conductors with 0.6...0.8 mm Ø
- A5 LED for indicating normal operating mode (LED off) or programming mode (LED on); returns to normal operating mode automatically after receiving the physical address
- A6 Programming button for switching between normal operating mode and programming mode and for receiving the physical address
- A7 1/2 inch screw nut
- A8 Wire (red) Load A (AWG #12)
- A9 Wire (black) Line (Hot) (AWG #12)
- A10 Wire (yellow) Load B (AWG #12)
- A11 Wire (pink) DIM Common (AWG #18)
- A12 Wire (purple) DIM A (AWG #18)
- A13 Wire (blue) DIM B (AWG #18)

### Mounting and Dismounting

- **Mounting of a JB module:**
  - Option 1 (mounting inside a J-Box)**
    - Insert the thread of the JB module (B2) into the 1/2 inch knockout between two adjacent J-Boxes (B1)
    - Fasten the JB module (B2) with the 1/2 inch thread nut (B4)
    - Remove the protective lid (B3) and connect the bus wire to the bus terminal block (A4)
    - Connect the wires from the device to the field wires using wire nuts (not provided in package)
  - Option 2 (mounting outside of a J-Box)**
    - Insert the thread of the JB module (B2) into the 1/2 inch knockout of the J-Box (B1)
    - Fasten the JB module (B2) with the 1/2 inch thread nut (B4) to the J-Box (B1)
    - Connect the bus wire to the bus terminal block under the protective cover (B3)
    - Connect the wires from the device to the field wires using wire nuts (not provided in package)

- **Assignment of the Physical Address:**
  - A short push (< 2 s) of programming button (A6) enables the programming mode, which is indicated when the LED is continuously on (A5). The device returns to normal operating mode (LED Off) automatically after receiving the physical address or if the programming button is pushed again.
  - A very long push (> 20 s) of the programming button resets the device to factory settings. This is indicated by constant flashing for 8 seconds.
- Install the protective lid (B3) and fasten with screws (provided in package)

- **Dismounting a JB module:**
  - Disconnect power to the module
  - Remove the wire nuts and bus connection
  - Unfasten the 1/2 inch thread nut (B4) connecting the JB module (B2) to the J-Box (B1)
  - Remove the JB module (B2) from the J-Box (B1)

### Wiring

#### Bus connection

##### Slipping off/on bus connection blocks

The bus connection block consists of two components (C2.1 and C2.2) with four terminal contacts each. Take care not to damage the two test sockets (C2.3) by accidentally connecting them to the bus cable or with the screw driver (e.g. when attempting to unplug the bus connection block).

##### Slipping off bus connection blocks

- Carefully put the screwdriver to the wire insertion slit of the bus connection block's black component (C2.2) and
- pull the bus connection block (C2) from the module.

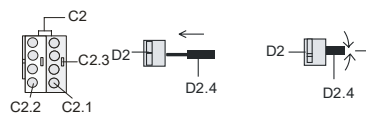
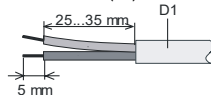

#### Note

Don't try to remove the bus connection block from the bottom side. There is a risk of shorting-out the device!

- B1 4" x 4" Junction Box
- B2 Device
- B3 Bus connection pins of the module for connection of the bus terminal block for single core conductors with 0.6...0.8 mm Ø
- B4 1/2 inch screw nut

#### Slipping on bus connection blocks

- Slip the bus connection block (C2) onto the guide slot of the module and
- press the bus connection block (C2) down to the stop.

#### Connecting and Disconnecting bus cables

##### Connecting bus cables

- The bus connection block (D2) can be used with single core conductors Ø 0.6...0.8 mm.
- Remove approx. 5 mm of insulation from the conductor (D1) and plug it into the bus connection block (D2) (red = +, black = -)

##### Disconnecting bus cables

- Unplug the bus connection block (D2) and remove the bus cable conductor (D1) while simultaneously wiggling it.

#### Connecting mains and load circuit:

##### Connect wires

- Connect wire leads using wire nuts.

### Dimension Diagram

Dimensions in mm (inch)

