

07 B0 A1 Switch actuator 982D02

Table of contents

Use of the application program	1
1. Functional description	1
Behavior at bus voltage failure / recovery	2
Building site function	2
Factory default state	2
Behavior on unloading the application program	2
Resetting the device to factory default settings	2
2. Communication objects	3
3. Functions (Objects, Parameters)	3
Switching (Normal mode)	4
Switching (timer mode)	6
Logic operation	7
Manual override	8
Night mode	8
Forced control	9
Switching status	10
Scene control	11
Counting of switching cycles	13
Counting of operating hours	15

Use of the application program

Product family:	Room Controller
Product type:	Output
Manufacturer:	Siemens
Name:	Switching Actuator RL 512/23
Description:	Switching Actuator, 1 x 16 A, AC 230 V
Order no.:	5WG1512-4AB23
Name:	Switching Actuator JB 512C23
Description:	Switching Actuator, 1 x 20 A, AC 120-277 V or 1 x 15 A, AC 347 V
Order no.:	5WG1512-4CB23

1. Functional description

The application program "07 B0 A1 Switch actuator 982D02" can be used for the KNX devices listed in section "Use of the application program". These devices are briefly described in the next sections.

The RL 512/23 Switching actuator is a KNX device with one switching output. The device is installed in an AP 118 Control Module Box, AP 641 Room Control Box or M 590 DIN rail housing. The bus is connected via a bus terminal block. The actuator electronics are supplied via the bus voltage.

The JB 512C23 Switching actuator is a KNX device with one switching output. The device is installed in a UL/NEMA junction box with minimum 4 inch length, 4 inch width and 2 inch depth. The bus is connected via a bus terminal block. The device electronics are supplied via the bus voltage.

These devices share the following features.

The device can switch resistive loads (e.g. electrical heaters, incandescent lamps, high voltage halogen lamps), inductive loads (e.g. motor, low voltage halogen lamps with intermediate conventional transformers), or capacitive loads (e.g. low voltage halogen lamps with intermediate electronic transformers).

The actuator output may be configured to provide switching, manual override, forced control, logical gate, and status reporting. Furthermore, if required, time-limited switching instead of permanent switching on can be enabled via an optional "Night mode" object (e.g. for lighting while cleaning), if need be with a warning before switching off by multiple switching the output on and off (flashing).

The following schema shows the named features in a logical overview.

07 BO A1 Switch actuator 982D02

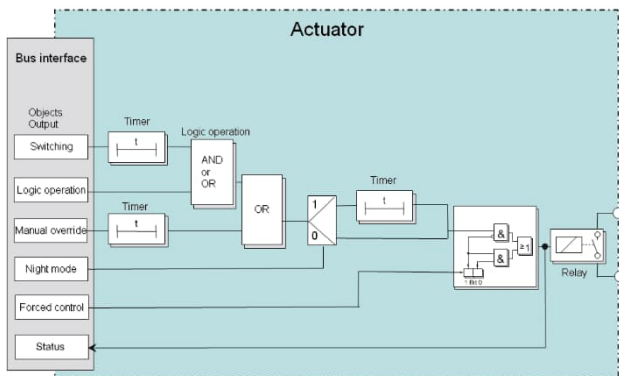

Schematic design of a switching actuator channel

Amongst others, the application program includes optional a switching cycle and operating hours count with threshold monitoring and an integrated 8-bit scene control, in which the output can be incorporated into up to 8 scenes.

The output of the actuator may be set to one of the following operating modes:

- Normal operation
- Timer operation

Behavior at bus voltage failure / recovery

Because the device electronics are powered by bus voltage a mains power failure only leads to a functional failure of the actuator if the bus voltage fails due to a failure of the mains voltage.

The actuator output is individually configurable regarding which switching position it shall take on bus voltage failure (Off, On, or No change) and which switching position it shall take on bus voltage recovery (Value prior to bus voltage failure, On, Off, or No change).

On bus voltage failure the current switching status value is saved for restoration on bus voltage recovery.

On bus voltage recovery the configured actions are executed and, if applicable, new status values are reported.

Building site function

The building site function provided ex-factory enables switching the building site lighting on and off via bus wall switches and actuators, even if these devices have not yet been commissioned with ETS.

Factory default state

In the default factory state all channels (outputs) are set to the function "switching" for the building site function.

Behavior on unloading the application program

When the application program is unloaded with ETS the device does not function.

Resetting the device to factory default settings

A very long push of the programming button (> 20 s) effects a reset to factory settings. This is indicated by constant flashing for 8 seconds.

All configuration settings are lost. The building site function is re-activated.

Addressing mode

A short push of learning button (< 2 s) enables the addressing mode. This is indicated by a continuously lit programming mode LED. A second push disables this mode.

Note

A long push of the learning button (> 5 s and <20 s) enables the Connection Test for commissioning with Desigo. Any time this mode can be disabled by a short push of the learning button.

07 BO A1 Switch actuator 982D02

2. Communication objects

Maximum number of group addresses: 120
 Maximum number of assignments: 120

Note

The number and names of communication objects visible can vary depending on the parameter settings.

The application program already has been loaded in the factory.

The device is configured and commissioned with Engineering Tool Software (ETS) version ETS v3.0f or higher. With the ETS (Engineering Tool Software) the specific parameters and addresses are assigned appropriately, and downloaded into the device.

The following list shows all objects of the device. Which objects are visible and linkable to group addresses is defined via the functions assigned to the inputs. The objects and associated parameter settings are described with the functions.

No.	Object name	Function	Number of bits	Flags
1	A 8-bit Scene	recall / store	1 Byte	CW
2	A Night mode	On/Off	1 Bit	CRW
3	A Manual override	On/Off	1 Bit	CRW
4	A Forced control	On/Off	2 Bit	CRW
5	A Switching	On/Off	1 Bit	CRWT
6	A Logic operation	On/Off	1 Bit	CRW
7	A Status Switching	On/Off	1 Bit	CRWT
8	A Threshold for switching cycles	Value	4 Byte	CRW
9	A Number of switching cycles	Value	4 Byte	CRW
10	A Exceedance of threshold for switching cycles	On/Off	1 Bit	CRWT
11	A Threshold for operating hours	Value	4 Byte	CRW
12	A Operating hours	Value	4 Byte	CRW
13	A Exceedance of threshold for operating hours	On/Off	1 Bit	CRWT

3. Functions (Objects, Parameters)

The actuator output can be configured with the following partial functions:

- Switching (Normal mode)
- Switching (Timer mode)
- Logic operation
- Manual override
- Night mode
- Forced control
- Switching status messaging
- Number of switching cycles with or without threshold monitoring
- Number of operating hours with or without threshold monitoring
- 8-bit scene control

The following sections describe the functions, which can be configured for the channel, including the associated objects and parameter settings.

Note

The number and names of the parameter windows in the ETS menus may vary as they are controlled via parameter settings.

Another parameter window may appear if due to dynamically added parameters the space in the first parameter window is exhausted.

07 BO A1 Switch actuator 982D02

Switching (Normal mode)

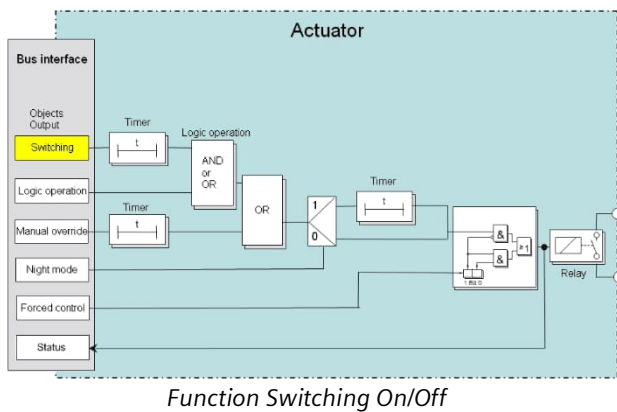

Objects

Obj	Object name	Function	Type	Flags
5	A Switching	On / Off	1 Bit	CRWT

Via this object switching telegrams are received in normal or timer mode which are forwarded where necessary to the corresponding output via the timer function. If a logic operation is configured in normal or timer mode, then the result of the timer function is the 1st value for the logic combination for the corresponding output.

Parameter „A Functions, Objects“

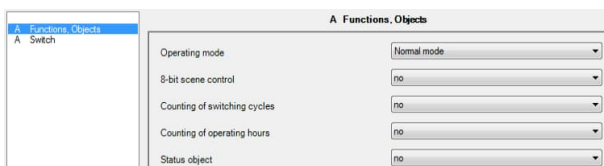

This parameter window offers selection of the base function (normal mode / timer mode) and of further functions of this actuator output channel. This includes,

- whether an 8-bit scene control shall be added,
- whether a status object shall be added for this output channel,
- whether the switching cycles of this output channel shall be counted with or without an upper threshold,
- whether the operating hours for this output channel shall be counted with or without an upper threshold.

Parameter	Settings
Operating mode	Normal mode; Timer mode

This parameter determines whether the corresponding output operates as a "normal" permanent switch or as a timer.

The parameter „Operation mode“ is set to “Normal mode“.

The other parameters are covered in the sections

- Scene control,
- Counting switching cycles,
- Counting operating hours and
- Switching status.

Parameter „A Switch“

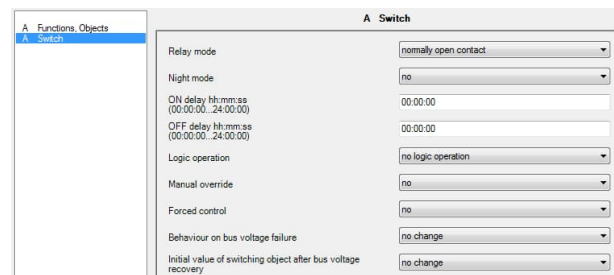

This parameter window is used to set the switching behavior in "Normal mode" of the corresponding actuator output channel..

The parameter window for the output channel is used to set

- whether the output operates as normally open or normally closed contact,
- whether night mode with a time- controlled “On” period is desired, and how long the “On” period is,
- whether in night mode a warning before switching off shall be executed,
- whether an “on” delay shall be executed and how long the period for the on delay is,
- whether an “off” delay shall be executed and how long the period for the off delay is,
- whether a logic operation is desired,
- whether a permanent or time-limited manual override to On shall be possible,
- whether forced control has to be provided,
- which switching status the output shall take on bus voltage failure and which value the switching object, and where applicable the logic object shall take on bus voltage recovery.

07 B0 A1 Switch actuator 982D02

Parameter	Settings
Relay mode	normally open contact normally closed contact
<p>This parameter determines the behavior of the output (relay contact). With the "normally closed contact" setting, "Switch off" always means closing the contact and "Switch on" always means opening the contact.</p> <p>"normally open contact": Off telegram = contact open, On telegram = contact closed.</p> <p>"normally closed contact": Off telegram = contact closed, On telegram = contact open.</p>	
ON-delay in hh:mm:ss (00:00:00...24:00:00)	00:00:00
<p>This parameter sets the wanted on-delay time. The default value 00:00:00 means that ON commands are executed immediately. A set on-delay acts only on the "Switching" object and not on an object for a logic operation allocated to the output as well.</p>	
OFF-delay hh:mm:ss (00:00:00...24:00:00)	00:00:00
<p>This parameter sets the wanted off-delay time. The default value 00:00:00 means that OFF commands are executed immediately. A set off-delay acts only on the "Switching" object and not on a linking object allocated to the output as well.</p>	
Behavior on bus voltage failure	Off On no change
<p>You use this parameter to set the wanted switching state of the output in the event of a bus voltage failure. If the bus voltage fails, the current switching state (if need be after execution of the configured switching command) will be saved permanently.</p>	
Initial value of switching object after bus voltage recovery	Off On no change as before bus voltage failure
<p>You use this parameter to set the wanted switching state of the output in the event of bus voltage recovery. If the parameter is set to "as before voltage failure", then the output is set to the state stored at the time of the bus voltage failure.</p>	
Initial value of logic operation object after bus voltage recovery	Off On as before bus voltage failure
<p><i>This parameter is visible only if the parameter "Logic operation" is <u>not</u> set to "no logic operation".</i> You use this to set the wanted start value of the logic input after bus voltage recovery. If the parameter is set to "as before bus voltage failure", then the logic input is set to the value of the logic object stored at the time of the bus voltage failure.</p>	

- Night mode,
- Logic operation,
- Manual override, and
- Forced control.

The other parameters are covered in the sections

07 BO A1 Switch actuator 982D02

Switching (timer mode)

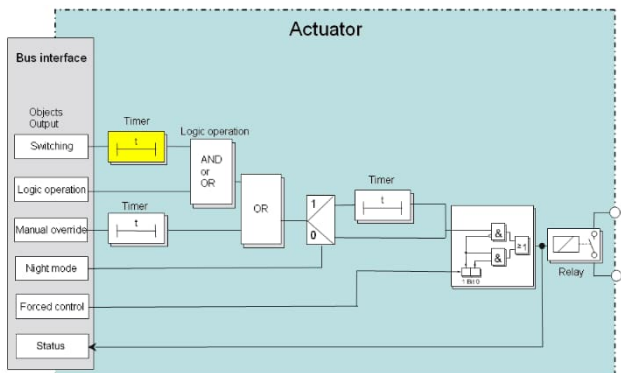

Switching (timer mode)

Objects

Obj	Object name	Function	Type	Flags
5	A Switching	On / Off	1 Bit	CRWT

Via this object switching telegrams are received in normal or timer mode which are forwarded where necessary to the corresponding output via the timer function. If a logic operation is configured in normal or timer mode, then the result of the timer function is the 1st value for the logic combination for the corresponding output.

Parameter „A Functions, Objects“

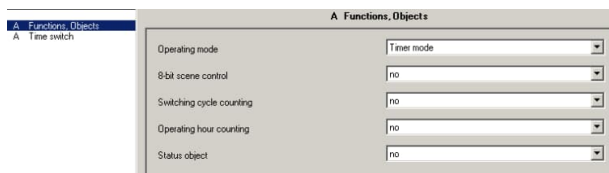

This parameter window offers selection of the base function (normal mode / timer mode) and of further functions of this actuator output channel. This includes,

- whether an 8-bit scene control shall be added,
- whether a status object shall be added for this output channel,
- whether the switching cycles of this output channel shall be counted with or without an upper threshold,
- whether the operating hours for this output channel shall be counted with or without an upper threshold.

Parameter	Settings
Operation mode	Normal mode; Timer mode

This parameter determines whether the corresponding output operates as a "normal" permanent switch or as a timer.

The parameter „Operation mode“ is set to “Timer mode”. The other parameters are covered in the sections

- Scene control,
- Counting switching cycles,
- Counting operating hours and
- Switching status.

Parameter „A Time switch“

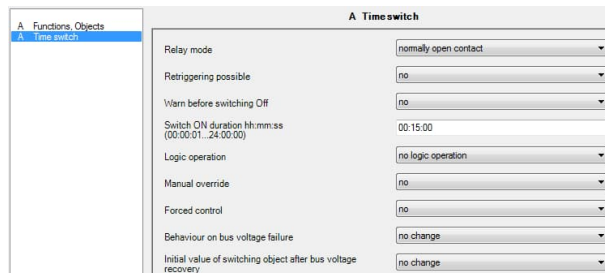

This parameter window is used to set the switching behavior in "Timer mode" of the corresponding actuator output channel..

The parameter window for the output channel is used to set

- whether the output operates as normally open or normally closed contact,
- whether the timer may be re-triggered,
- whether a warning before switching off shall be executed,
- how long the timer period shall be,
- whether a logic operation is desired,
- whether a permanent or time-limited manual override to On shall be possible,
- whether forced control has to be provided,
- which switching status the output shall take on bus voltage failure and which value the switching object, and where applicable the logic object shall take on bus voltage recovery.

07 BO A1 Switch actuator 982D02

Parameter	Settings
Relay mode	normally open contact normally closed contact
This parameter determines the behavior of the output (relay contact). With the "normally closed contact" setting, "Switch off" always means closing the contact and "Switch on" always means opening the contact. " normally open contact": Off telegram = contact open, On telegram = contact closed. " normally closed contact": Off telegram = contact closed, On telegram = contact open.	
Retriggering possible	no yes
This parameter sets whether on receiving a new ON telegram during an on-period, this is restarted and thus the on-time is to be extended.	
Warn before switching Off	no yes
You use this parameter in night mode to set the output such that it is not switched off immediately when the configured time has elapsed, but is switched off initially for only 1 second and is then switched on again for 10 seconds. This is repeated twice more before the output is then switched off permanently. If the output is used for lighting control, then a user is given advance warning and has time enough to switch the lighting on again.	
On-time in hh:mm:ss (00:01:00...24:00:00)	00:15:00
This parameter sets the wanted on-time for the output in timer mode.	
Behavior on bus voltage failure	Off On no change
You use this parameter to set the wanted switching state of the output in the event of a bus voltage failure. If the bus voltage fails, the current switching state (if need be after execution of the configured switching command) will be saved permanently.	
Initial value of switching object after bus voltage recovery	Off On no change as before bus voltage failure
You use this parameter to set the wanted switching state of the output in the event of bus voltage recovery. If the parameter is set to "as before bus voltage failure", then the output is set to the state stored at the time of the bus voltage failure.	

The other parameters are covered in the sections

- Logic operation,
- Manual override, and
- Forced control.

Night mode is not possible in combination with timer mode.

Logic operation

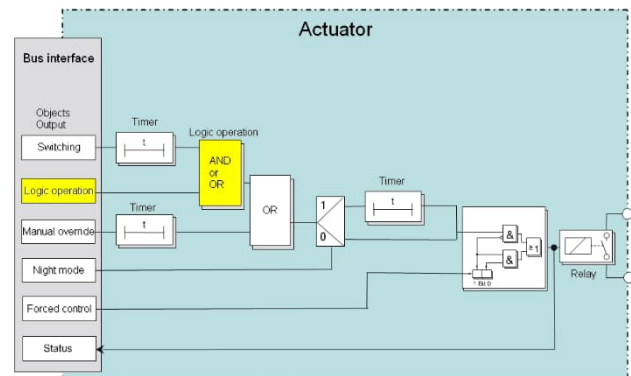

Logic operation

Objects

These additional objects appear.

Obj	Object name	Function	Type	Flags
6	A Logical operation	On / Off	1 Bit	CRW
Via this object the switching information for the 2nd input of the logic operation to the corresponding output are received. If the parameter setting is "no logic operation", this object is not needed and is therefore not displayed.				

Parameters

Parameter	Settings
Logical operation	no logical operation AND operation OR operation
If need be, the switching of the output via a logic operation can be complemented with an object "A Logical operation" as well. The logic operation object is not subject to a time delay, i.e. the logic operation is always effective immediately.	
Initial value of logic object after bus voltage recovery	Off; On; as before voltage failure
<i>This parameter is visible only if the parameter "Logic operation" is <u>not</u> set to "no logic operation".</i> You use this to set the wanted start value of the logic input after bus voltage recovery. If the parameter is set to "as before bus voltage failure", then the logic input is set to the value of the logic object stored at the time of the bus voltage failure.	

07 BO A1 Switch actuator 982D02

Manual override

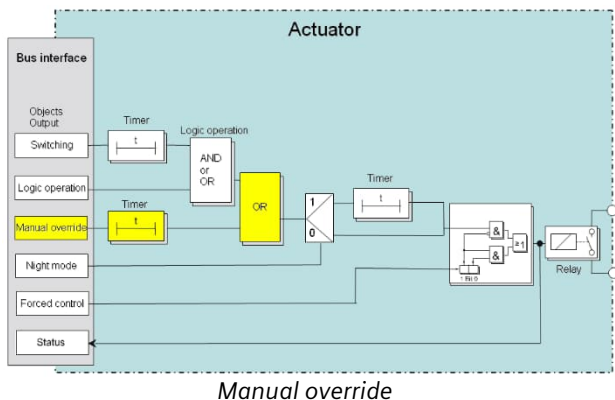

Night mode

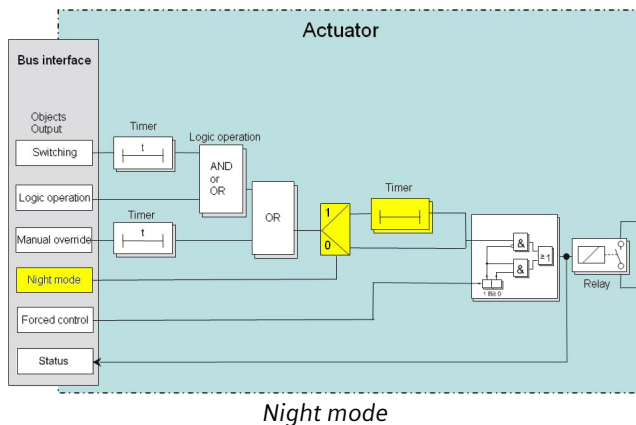

Objects

These additional objects appear.

Obj	Object name	Function	Type	Flags
3	A Manual override	On / Off	1 Bit	CRW

This object enables an output that has been switched OFF via its "normal" switching input (if need be, with a logic operation) to be switched back on permanently or for a time-limited period. This object only switches off the relevant output if the latter has also been switched off via its "normal" switching input (if need be, with a logic operation). In other cases, the output remains switched on. If the parameter setting is "Manual override = No", this object is not needed and is therefore not displayed.

Parameter

Parameter	Settings
Manual override	No yes yes, time-limited
This parameter determines whether an additional object "A Manual override", via which an output switched off by the "normal" switching input (if need be with a logic operation) can be switched on again permanently or for a set time, is to be added to this output. This object only switches off the output if the latter has been switched off before via the "normal" switching input (if need be, with a logic operation). In other cases, the output remains switched on.	
Manual override period in h:mm:ss (0:00:05...8:00:00)	0:05:00
<i>This parameter is visible only if the previous parameter "Manual override" is set to "Yes, time-limited".</i>	
This parameter determines the on-period with manual override.	

Via an optional object "Night mode" for the output, it can be, if desired, controlled to switch on for a limited time only (e.g. for cleaning crew lighting) instead of permanently switching on. The time limited switching may be configured with warning before turning off with repeated off-on-switching of the output (flashing).

Objects

These additional objects appear.

Obj	Object name	Function	Type	Flags
2	A Night mode	On / Off	1 Bit	CRW

This objects enables or disables "Night mode" for the corresponding output via the bus. The control signal can be sent by a button, a timer or an automatic building management system, for example. If a logical one is received, then the corresponding output switches to night mode. In "Night mode" the output can no longer be switched on permanently, but only for a limited time (for example, lighting for cleaning for 30 minutes). If the "Warning before switching off" parameter (see corresponding "Behavior" parameter window) is set to "Yes" then, in night or timer mode, before the configured ON time has elapsed, you are informed, by the lighting switching on and off three times, that approximately 30 seconds after the first switching off the output will be switched off permanently. This lets you know the end of the ON time and by pressing the light switch again, the lighting will be left ON for a further 30 minutes, for example. If the parameter setting is "Night mode = No", this object is not needed and is therefore not displayed.

07 BO A1 Switch actuator 982D02

Parameters

Parameter	Settings
Night mode	no yes
This parameter determines whether an additional "Night mode" communication object is activated for this output. If night mode is on, the output can no longer be switched on permanently but only for a time-limited period (e.g. for lighting for cleaning). If you set this parameter to "yes", then the following parameters "On-time during night mode in hh:mm:ss" and "Warn before switching off" are added.	
Warn before switching Off	no yes
You use this parameter in night mode to set the output such that it is not switched off immediately when the configured time has elapsed, but is switched off initially for only 1 second and is then switched on again for 10 seconds. This is repeated twice more before the output is then switched off permanently. If the output is used for lighting control, then a user is given advance warning and has time enough to switch the lighting on again.	
ON-time during night mode in hh:mm:ss (00:00:10...24:00:00)	00:30:00
<i>This parameter is visible only if the previous parameter "Night mode" is set to "yes".</i> This parameter determines the on-time in night mode.	

Forced control

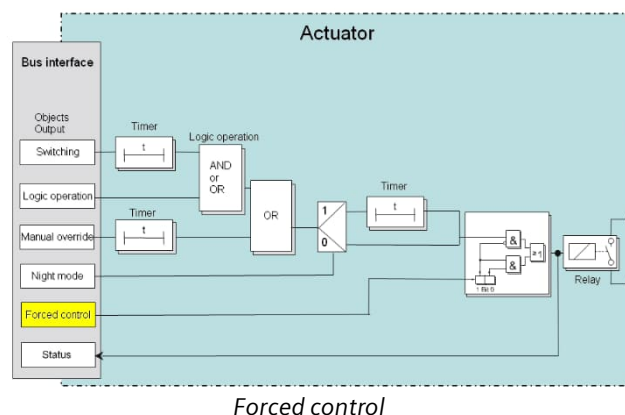

Actuators with forced control allow overriding certain actuator outputs by central control commands. In energy savings mode or at night turning selected luminaires or loads on may be forced to be blocked.

Objects

These additional objects appear.

Obj	Object name	Function	Type	Flags
4	A Forced control	On / Off	2 Bit	CRW
These 2-bit objects enable a forced switching on or off of the corresponding output, regardless of all other objects impacting on the output.				
Bit 1 determines whether the forced control is "active" (= 1) or "passive" (0). If bit 1 = 0, then the forced control is "passive" and the switching input is available directly at the forced control output. If bit 1 of the forced control object = 1, then the forced control is "active" and the switching input is disabled. In this case, bit 0 of the forced control object determines the value of the internal forced control output. If forced control is blocked, the switching input is available directly at the internal output of the forced control function.				
	Bit 1	Bit 0	Function	
	0	0	Forced control disabled	
	0	1	Forced control disabled	
	1	0	Force controlled OFF	
	1	1	Force controlled ON	

07 BO A1 Switch actuator 982D02

Parameters

Parameter	Settings
Forced control	no yes

If necessary, you use this parameter to add the 2-bit object "X-n: Forced control", which allows forced switching on or off of the output, regardless of any other objects acting on the output. Bit 1 determines whether the forced control is "active" (= 1) or "passive" (0). If bit 1 = 0, then the forced control is "passive" and the switching input is available directly at the forced control output. If bit 1 of the forced control object = 1, then the forced control is "active" and the switching input is disabled. In this case, bit 0 of the forced control object determines the value of the internal forced control output. If forced control is blocked, the switching input is available directly at the internal output of the forced control function.

Bit 1	Bit 0	Function
0	0	Forced control disabled
0	1	Forced control disabled
1	0	Force controlled OFF
1	1	Force controlled ON

Switching status

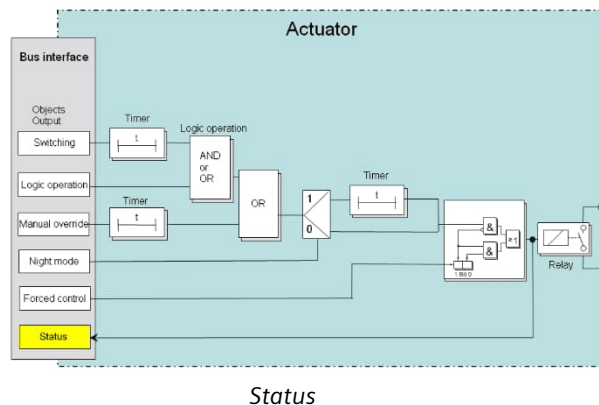

Objects

These additional objects appear.

Obj	Object name	Function	Type	Flags
7	A Status Switching	On / Off	1 Bit	CRWT

The current switching state of the corresponding output is stored in the status object and this can be queried by a read request or will be sent automatically after each object value change according to the corresponding configuration. If the parameter setting is "Switching status object = no", this object is not needed and is therefore not displayed.

Parameter „A Functions, Objects“

Parameter	Settings
Status object	no yes
This parameter determines whether a "A Status switching" communication object is available for the corresponding output. For example, the status object can be used to display the current output switching status on a display, a panel or a PC with visualization software.	
Send status and threshold objects	on request on request and on change of status
This parameter is visible if one of the functions Status Switching, Counting of switching cycles or counting of operating hours is activated.	
This sets when the status and threshold objects are to be sent (only on request or on request and automatically after each status change).	

07 BO A1 Switch actuator 982D02

Parameter	Settings
Transmission blocking period for status object in seconds after bus voltage recovery (1...15)	1 [1...15]
<p><i>This parameter is visible if the parameter "Send status and threshold objects" has been set to "on request and on change of status".</i></p> <p>In order to avoid a prohibitively high bus load by simultaneous sending of numerous status / threshold objects after bus voltage recovery or after a restart of the main module, you can set an individual transmission blocking period. The status / threshold objects will be sent only after this has elapsed.</p>	

Scene control

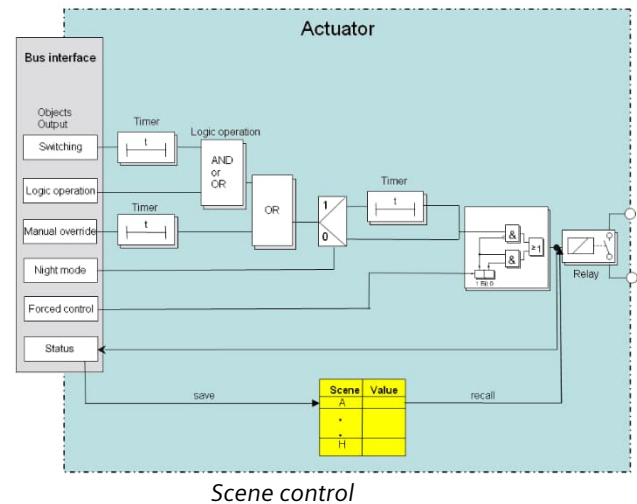

The "8-bit scene recall / store" function enables the user to change the characteristics of a preset scene stored in scene controllers for 8 bit scene control or in actuators with integrated 8 bit scene control, i.e. the user can change brightness levels and switching states of the groups within a scene, without changing the configuration using the ETS.

There is one communication object for transmitting the commands for saving the 8-bit scene and recalling the saved scene using the target scene number.

Before saving a scene the actuators belonging to that scene must be set to the desired light levels and switching states. When receiving a save telegram scene controllers or actuators with 8-bit scene function are commanded to interrogate the current light levels and switching states of the actuators and save these as scene settings.

The scenes refer to the object value of the switching object. When a scene is recalled then the associated value (On / Off) is internally written to the switching object as if an external telegram had been received. The actuator acts as if a switching message had been received via the bus. When a scene is saved the current value of the switching object is saved.

Note: If a scene is recalled before the corresponding values have been saved then there is no reaction to that scene recall.

07 BO A1 Switch actuator 982D02

Objects

These additional objects appear.

Obj	Object name	Function	Type	Flags
1	A 8-bit Scene	recall / store	1 Byte	CW

This object is used to recall (restore) or program the 8-bit scene with the number x (x = 1...64).
 Bits 0...5 contain (in binary code) the number of the wanted scene as a decimal number between 1 and 64 (in which the decimal number 1 equals the binary number 0, the decimal number 2 equals the binary number 1, etc.). If bit 7 = logical 1, then the scene is programmed and if bit 7 = logical 0, then it is recalled. Bit 6 is currently spare and must be set to logical 0.

Parameter „A Functions, Objects“

Parameter	Settings
8-bit scene control	no yes

Use this parameter to set whether the 8-bit scene control incorporated in the switching actuator is to be enabled. If so, the corresponding communication object and the parameter window "A 8-bit scene control" are added for assignment of up to 8 scene numbers per output.

Parameter „A 8-bit Scenes“

Parameter	Settings
8-bit scenes programmable	no; yes
This parameter applies to all 8 scene links. If "yo" is selected, scenes cannot be programmed (via a scene telegram). The scene recall values for the relay position set with the parameter "Switch position" cannot be changed during operation. If "yes" is selected, for each activated Link two additional parameters appear: "Link x delete learned scene" and "Link x predefine scene".	
Link 1 with scene [1...64] (0 = disable)	0 1 ... 64
Link 2 with scene [1...64] (0 = disable)	0 1 ... 64
Link 3 with scene [1...64] (0 = disable)	0 1 ... 64
Link 4 with scene [1...64] (0 = disable)	0 1 ... 64
Link 5 with scene [1...64] (0 = disable)	0 1 ... 64
Link 6 with scene [1...64] (0 = disable)	0 1 ... 64
Link 7 with scene [1...64] (0 = disable)	0 1 ... 64
Link 8 with scene [1...64] (0 = disable)	0 1 ... 64
Each of these parameters assigns the output of the actuator to an 8-bit scene with a number in the range of 1 to 64. „0“ means that the specific assignment is not used. Note: If a scene is recalled before the corresponding values have been saved then there is no reaction to that scene recall.	
Link x delete learned scene	no; yes
This parameter is only visible for an activated link, if the parameter "8-bit scene programmable" is set to "yes". If this parameter is set to "no" then the saved scene values are not deleted when the configuration is downloaded to the device using the ETS.	

07 BO A1 Switch actuator 982D02

Parameter	Settings
	If this parameter is set to "yes" then the saved scene values are deleted when the device configuration is downloaded into the device using the ETS.
Link x predefine scene values	no; yes
	<i>This parameter is only visible for an activated link if the parameter "8-bit scene programmable" is set to "yes" and the parameter "Link x delete learned scene" is set to "yes".</i> If this parameter is set to "no" then the associated parameter "Switch position" is invisible. A scene must be saved by the user. Already saved scene values remain when the configuration is downloaded with the ETS. If the user does not set a scene value then the factory default value ("0") applies. If this parameter is set to "yes" then the associated parameter "Switch position" appears. The value set with that parameter is downloaded into the device with the ETS.
Switch position	Off; On
	<i>This parameter is only visible for an activated link if the parameter "8-bit scene programmable" is set to "no" or the parameters "8-bit scene programmable", "Link x delete learned scene" and Link x predefine scene" are set to "yes".</i> This parameter is used during configuration to preset the switching position for the selected scene number.

Counting switching cycles

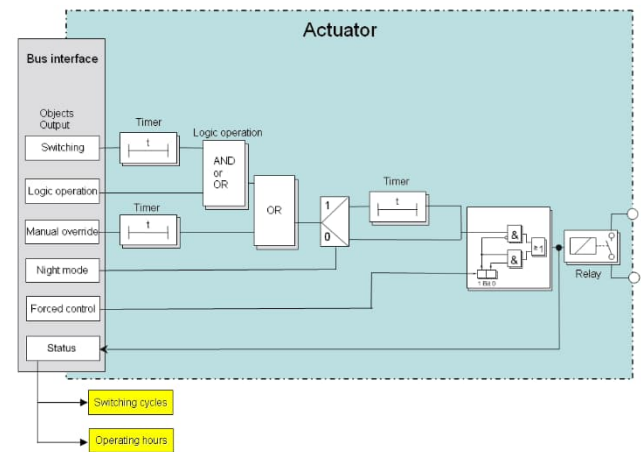

Counting of switching cycles and operating hours

Counting switching cycles enables monitoring of the connected load.

The counter is incremented with each change from "Off" to "On" (in normally open configuration) respectively from "On" to "Off" (in normally closed configuration). In case of warning before switching off, each switching (flashing) is counted. If switching is configured in case of bus power failure and if with this switching the switching cycle threshold is exceeded, then this is transmitted after bus power recovery.

The object "Exceeding switching cycles threshold" is only transmitted (once) on change of value. If a new threshold is received or the switching cycle counter is reset then the value of the object "Exceeding switching cycles threshold" is only transmitted on change of value of this object.

When the counter object has reached its maximum possible value (4 294 967 295) then its value is retained until it is reset.

The value is reset by writing a value to the object for the (current) switching cycle value.

On bus voltage failure the values of all three objects for switching cycle counting are saved in order to restore them on bus voltage recovery.

The three objects are not reset by a download.

Switching cycle counting is active even if the parameter "Counting of switching cycles" is set to "No".

07 BO A1 Switch actuator 982D02

Objects

These additional objects appear.

Obj	Object name	Function	Type	Flags
8	A Threshold for switching cycles	Value	4 Byte	CRW
Via this object the threshold for the switching cycle count for the relevant output can be sent as an integer value between 1 and 4 294 967 295 to the switching actuator via the bus. This object is only available if the parameter "Switching cycle counting" in the "A Functions, Objects" parameter window is set in each case to "with threshold evaluation".				
9	A Number of switching cycles	Value	4 Byte	CRW
Via this object the number of switching cycles for the relevant output (1 switching cycle = switch output on and off again) can be sent at any time via the bus. This object is only available if the parameter "Switching cycle counting" in the "A Functions, Objects" parameter window is set either to "without threshold evaluation" or to "with threshold evaluation". If the parameter is set to "with threshold evaluation" then a telegram is sent when the threshold is exceeded.				
10	A Exceedance of threshold for switching cycles	On / Off	1 Bit	CRWT
Via this object the attaining or exceeding of the relevant switching cycle count threshold is reported via the bus respectively it can be queried whether the threshold is being exceeded. This object is only available if the parameter "Switching cycle counting" in the "A Functions, Objects" parameter window is set in each case to "with threshold evaluation".				

Parameter „A Functions, Objects“

Parameter	Settings
Switching cycles counting	no; without threshold evaluation; with threshold evaluation
This parameter enables counting of switching cycles (i.e. how often an output has been switched on and off again) for the corresponding output. If the parameter is set to "without threshold evaluation", then only the communication object "A Number of switching cycles" is added to this output. If the parameter is set to "with threshold evaluation", then the communication object "A Threshold for switching cycles", which prescribes a threshold and the communication object "A Exceeding switching cycles threshold", which reports the attaining or exceeding of the prescribed threshold, are also added.	
Send status and threshold objects	on request

Parameter	Settings
	on request and on change of status
<i>This parameter is visible if one of the functions Status Switching, Counting of switching cycles or counting of operating hours is activated.</i>	
This sets when the status and threshold objects are to be sent (only on request or on request and automatically after each status change).	
Transmission blocking period for status object in seconds after bus voltage recovery (1...15)	1 [1...15]
<i>This parameter is visible if the parameter "Send status and threshold objects" has been set to "on request and on change of status".</i>	
In order to avoid a prohibitively high bus load by simultaneous sending of numerous status / threshold objects after bus voltage recovery or after a restart of the main module, you can set an individual transmission blocking period. The status / threshold objects will be sent only after this has elapsed.	

07 BO A1 Switch actuator 982D02

Counting operating hours

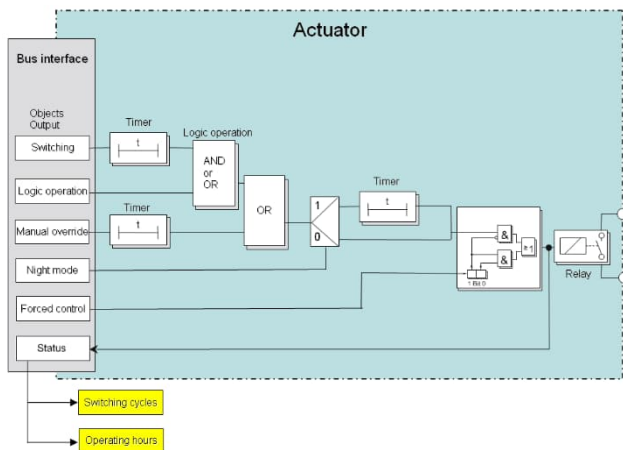

Counting of switching cycles and operating hours

Counting operating hours enables monitoring of the connected load.

The operating hours are counted while the switching status of the channel is "On". Counting is active when the relay configured as normally open is closed respectively when the relay configured as normally closed is open. Only full seconds are counted. The value of the object "Operating hours" is incremented by one when 3,600 seconds have been counted.

The object "Exceeding operating hours threshold" is only transmitted (once) on change of value. If a new threshold is received or the operating hours counter is reset then the value of the object "Exceeding operating hours threshold" is only transmitted on change of value of this object. When the counter object has reached its maximum possible value (4 294 967 295) then its value is retained until it is reset.

The value is reset by writing a value to the object for the (current) switching cycle value.

Operating hours cannot be counted on bus voltage failure.

On bus voltage failure the values of all three objects for switching cycle counting are saved in order to restore them on bus voltage recovery.

The three objects are not reset by a download.

Counting operating hours is active even if the parameter "Counting of switching cycles" is set to "No".

Objects

These additional objects appear.

Obj	Object name	Function	Type	Flag
11	A Threshold for operating hours	Value	4 Byte	CRW
Via this object the threshold for the operating hours count for the relevant output is sent as an integer value between 1 and 4 294 967 295 to the switching actuator via the bus. This object is only available if the parameter "Operating hour counting" in the "A Functions, Objects" parameter window is set in each case to "with threshold evaluation".				
12	A Operating hours	Value	4 Byte	CRW
Via this object the current number of operating hours for the relevant output (i.e. how many hours the output was ON) can be queried via the bus at any time. This object is only available if the parameter "Operating hour counting" in the "A Functions, Objects" parameter window is set either to "without threshold evaluation" or to "with threshold evaluation". If the parameter is set to "with threshold evaluation" then a telegram is sent when the threshold is exceeded.				
13	A Exceedance of threshold for operating hours	On / Off	1 Bit	KLSÜ
This object report attaining or exceeding the relevant operating hours count threshold or interrogate via the bus whether a threshold is being exceeded. This object is only available if the parameter "Operating hour counting" in the "A Functions, Objects" parameter window is set in each case to "with threshold evaluation".				

Parameter „A Functions, Objects“

Parameter	Settings
Operating hours counting	no; without threshold evaluation; with threshold evaluation
This parameter enables operating hours counting (i.e. for how many hours the output was switched on) for the corresponding output. If the parameter is set to "without threshold evaluation", then only the communication object "A Operating hours" is added to this output. If the parameter is set to "with threshold evaluation", then the communication object "A Threshold for operating hours", which prescribes a threshold and the communication object "A Exceeding operating hours threshold", which reports the attaining or exceeding of the prescribed threshold, are also added.	

07 B0 A1 Switch actuator 982D02

Parameter	Settings
Send status and threshold objects	on request on request and on change of status
<p><i>This parameter is visible if one of the functions Status Switching, Counting of switching cycles or counting of operating hours is activated.</i></p> <p>This sets when the status and threshold objects are to be sent (only on request or on request and automatically after each status change).</p>	
Transmission blocking period for status object in seconds after bus voltage recovery (1...15)	1 [1...15]
<p><i>This parameter is visible if the parameter "Send status and threshold objects" has been set to "on request and on change of status".</i></p> <p>In order to avoid a prohibitively high bus load by simultaneous sending of numerous status / threshold objects after bus voltage recovery or after a restart of the main module, you can set an individual transmission blocking period. The status / threshold objects will be sent only after this has elapsed.</p>	

Space for notes